

Pianeta

di Federico Scalabra

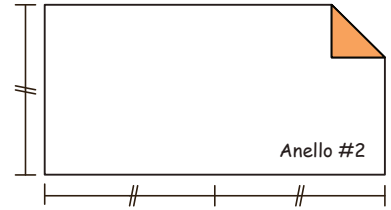

PIANETA

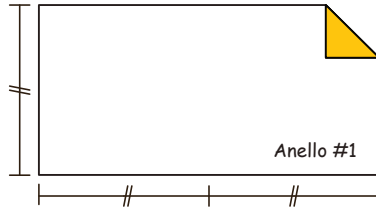
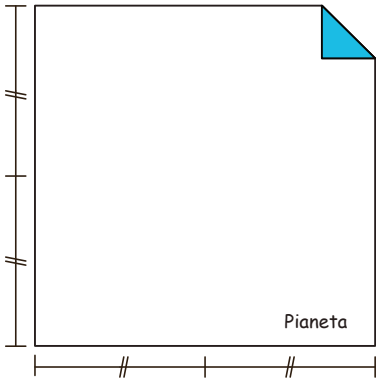
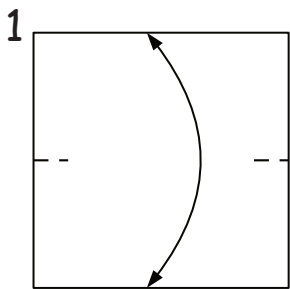

Colore sotto.

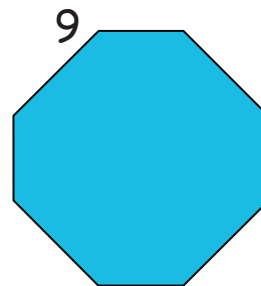
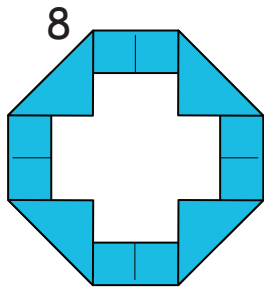
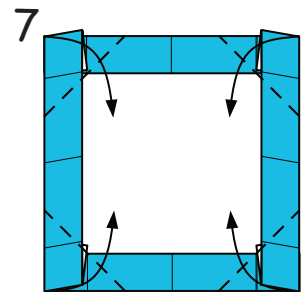
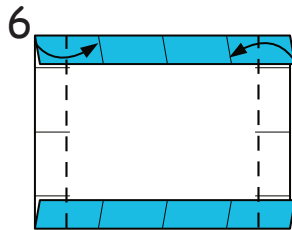
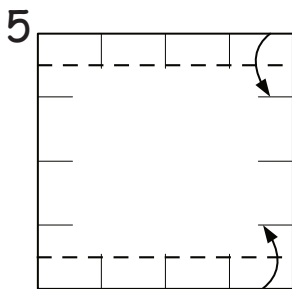
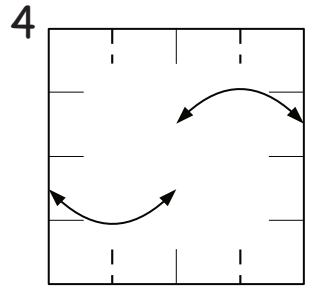
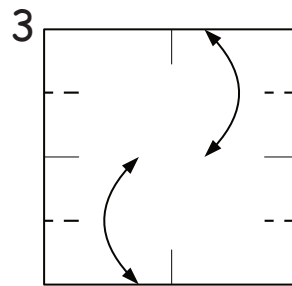
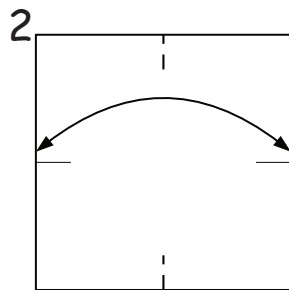

ANELLO #1

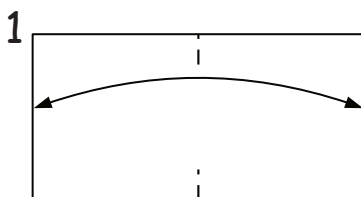

Colore sotto.

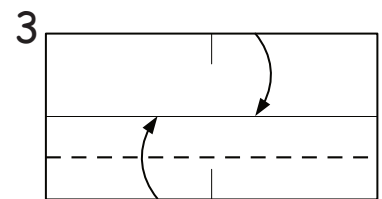
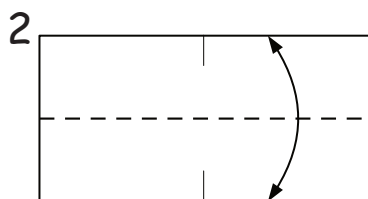

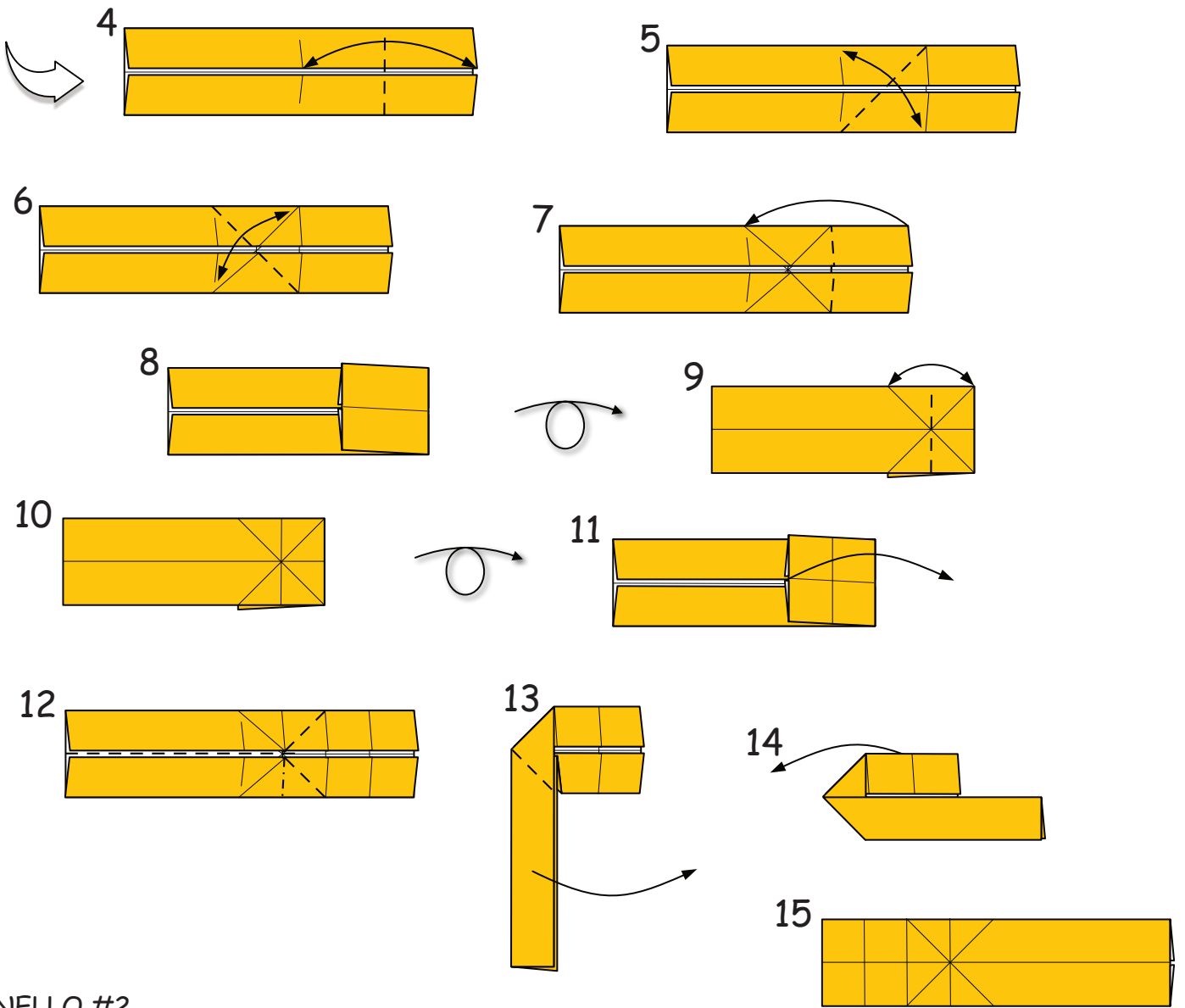

ANELLO #2

1 Piegare i passaggi 1-11 dell'anello #1.

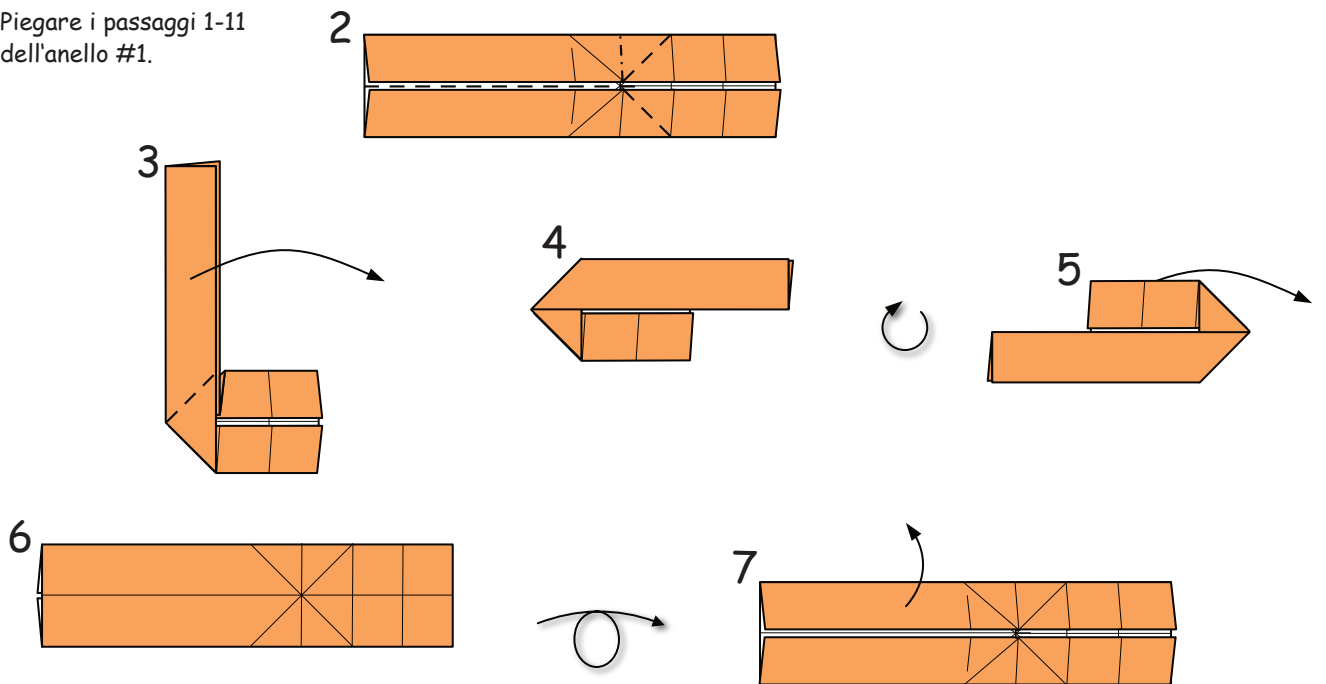

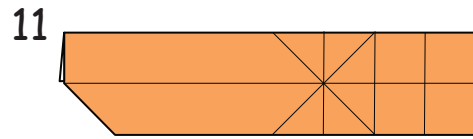
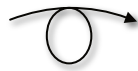
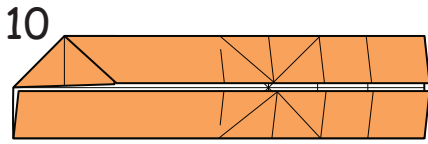
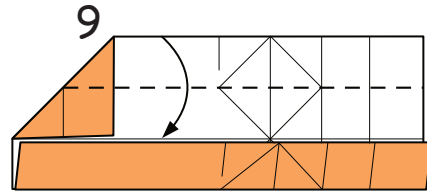
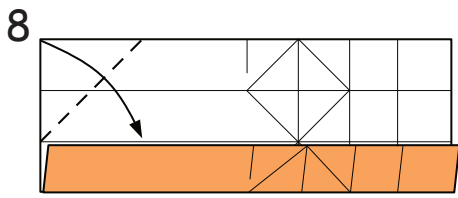

ASSEMBLAGGIO

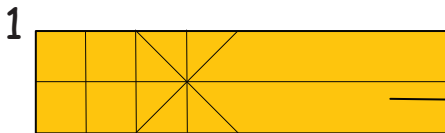

Intascare l'ANELLO #1 nell'ANELLO2.

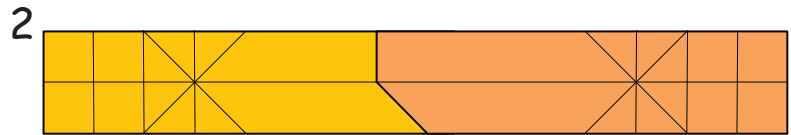
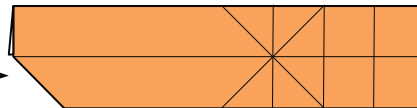

Riformare gli anelli seguendo le pieghe dei passaggi precedenti.

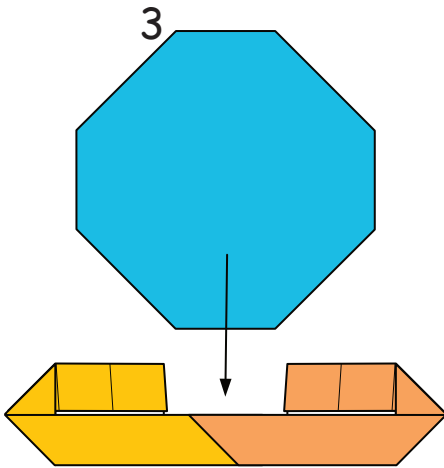

Inserire il pianeta tra gli anelli.

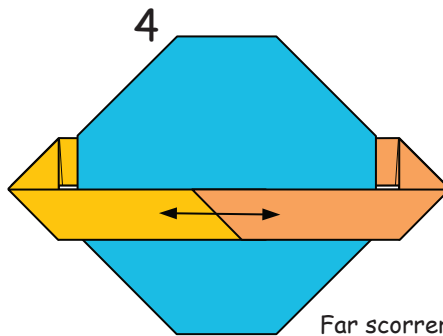

Far scorrere gli anelli per adattarli al pianeta.

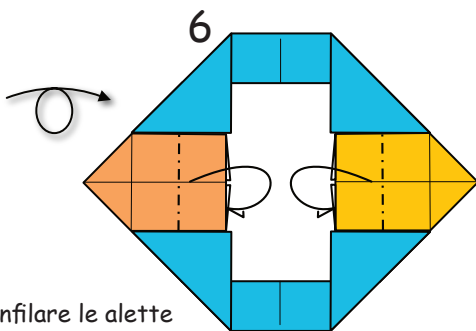
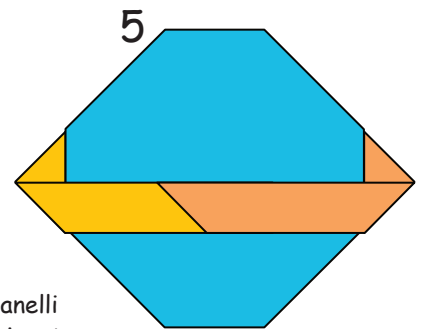

Infilare le alette nelle tasche.

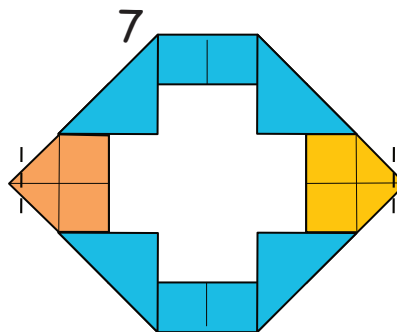

Sagomare gli anelli.

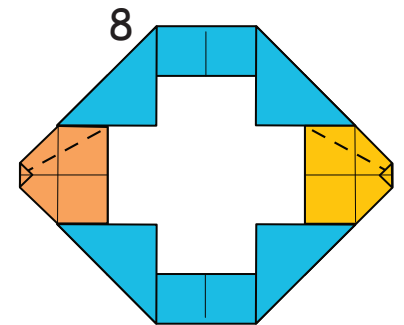

Sagomare gli anelli.

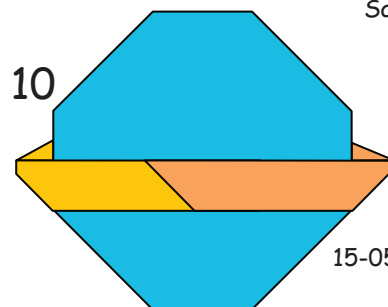
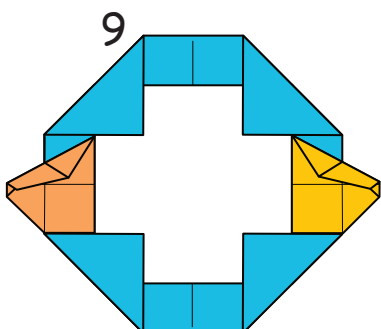

15-052022